



400 Series

404D-22G

Diesel Engine - Electropak

20.3 kWm @ 1500 rev/min
 23.9 kWm @ 1800 rev/min
 32.7 kWm @ 3000 rev/min



Powered by your needs

- The 404D-22G Electropak is a powerful but quiet 2.2 litre naturally aspirated 4-cylinder compact package

Compact, Clean, Efficient Power

- Design features on the 400D range of Electropaks ensures clean rapid starting in all conditions whilst delivering impressive performance with low operating costs in a small, efficient package size

Lower Operating Costs

- Approved for operation on biodiesel* concentrations of up to 20%.
- Oil and filter changes are 500 hours, dependent on load factor.
- Engine durability and reliability, the warranty offering and ease of installation combine to drive down the cost of ownership.

Long-term Power Solution

- The 400D range of Electropaks has been designed to fully comply with stringent EU and EPA emissions regulations, providing an emissions compliant power solution for the future (see 'Perkins Emissions Statement' on page 2).

World-class Product Support

- Through an experienced global network of distributors and dealers, fully trained engine experts deliver total service support around the clock, 365 days a year. They have a comprehensive suite of web based tools at their finger tips, covering technical information, parts identification and ordering systems, all dedicated to maximising the productivity of your engine.
- Perkins actively pursues product support excellence by insisting our distribution network invest in their territory to provide you with a consistent quality of support across the globe.
- Throughout the entire life of a Perkins engine, we provide access to genuine OE specification parts giving 100% reassurance that you receive the very best in terms of quality for lowest possible cost... wherever your Perkins powered machine is operating in the world.

The 400 Series engine family continues to set new standards in the compact engine market. Developed alongside customers to fulfill their needs in the Genset, Compressor, Agricultural and general Industrial markets.

These new Electropaks provide compact power, from a robust family of 3 and 4 cylinder diesel engines designed to provide economic and durable operation at Prime and Standby duties, hitting the key power nodes required by the power generation industry.

Engine Speed	Type of Operation	Typical Generator Output (Net)		Engine Power				Low Idle
				Gross		Net		
		kVA	kWe	kWm	bhp	kWm	bhp	
1500	Prime Power	20.3	16.2	18.7	25.1	18.4	24.7	n/a
	Standby Power	22.3	17.8	20.6	27.6	20.3	27.2	n/a
1800	Prime Power	24.2	19.3	22.0	29.5	21.7	29.1	n/a
	Standby Power	26.6	21.3	24.3	32.6	23.9	32.1	n/a
†3000	Prime Power	33.1	26.5	31.2	41.8	29.7	39.9	1600 ± 25
	Standby Power	36.4	29.1	34.4	46.1	32.7	43.9	1600 ± 25

*Subject to conformance with ASTM D6751 and EN14214.

† Regarding gen sets ≥ 3000 rev/min: The U.S. EPA has certified this engine as a **constant speed** engine, with engine speed controlled by a solenoid that allows operation only at idle or full power position. The solenoid is a required element of design. **It is the responsibility of the equipment manufacturer to install the proper solenoid.** Installation of this engine in equipment without the required solenoid (or in any manner that allows variable speed operation) is not covered by EPA certification, voids the emissions warranty, and may subject the equipment manufacturer to penalties under U.S. law¹.

The above ratings represent the engine performance capabilities to conditions specified in ISO 8528/1, ISO 3046/1:1986, BS 5514/1. Derating may be required for conditions outside these; consult Perkins Engines Company Limited. Generator powers are typical and are based on typical alternator efficiencies and a power factor (cos θ) of 0.8.

Fuel specification: BS 2869: Part 2 1998 Class A2 or ASTM D975 D2.

Rating Definitions: Prime Power: Power available at variable load in lieu of a main power network. Overload of 10% is permitted for 1 hour in every 12 hours operation. Standby (maximum): Power available at variable load in the event of a main power network failure. No overload is permitted.

Photographs are for illustrative purposes only and may not reflect final specification.

400 Series

404D-22G

Standard ElectropaK Specification

Air Inlet

- Mounted air filter

Fuel System

- Mechanically governed cassette type fuel injection pump
- Split element fuel filter

Lubrication System

- Wet steel sump with filler and dipstick
- Spin-on full-flow lub oil filter

Cooling System

- Thermostatically-controlled system with belt driven coolant pump and pusher fan
- Mounted radiator, piping and guards

Electrical Equipment

- 12 volt starter motor and 12 volt 65 amp alternator with DC output
- Oil pressure and coolant temperature switches
- 12 volt shut off solenoid energised to run
- Glow plug cold start aid and heater/starter switch

Flywheel and Housing

- 1500/1800 rev/min
- High inertia flywheel to SAE J620 Size 7½ Heavy
- Flywheel housing SAE 4 Long
- 3000 rev/min
- High inertia flywheel to SAE J620 Size 7½ Light
- Flywheel housing SAE 4 Short

Mountings

- Front and rear engine mounting bracket

Optional Equipment

- Workshop manual
- Parts book

Option Groups

A selection of optional items is available to enable you to prepare a specification precisely matched to your needs.

Emissions Statement

- **Constant Speed Engines** for use in Industrial, IOPU and ElectropaK applications: Certified against the requirements of EU Stage IIIA (Directives 97/68/EC, as last amended, for mobile applications); and US EPA Tier 4 Interim (40 CFR Parts 60 for stationary applications and 40CFR Part 1039 for mobile applications).



Perkins Engines Company Limited

Peterborough PE1 5NA
 United Kingdom
 Telephone +44 (0)1733 583000
 Fax +44 (0)1733 582240
www.perkins.com

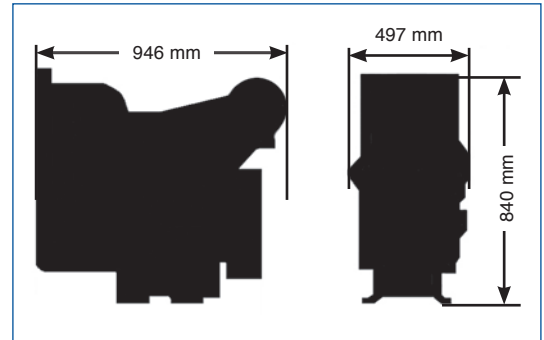

Engine Speed	Fuel Consumption			
	1800 rev/min		1500 rev/min	
	g/kWh	l/hr	g/kWh	l/hr
Standby	235	6.9	244	6.1
Prime power	233	6.2	237	5.3
75% of prime power	240	4.8	238	4.0
50% of prime power	262	3.5	258	2.9

General Data

Number of cylinders	4
Cylinder arrangement	Vertical in-line
Cycle	4 stroke
Aspiration	Naturally aspirated
Combustion system	Indirect injection
Compression ratio	23.3:1
Bore and Stroke	84 x 100 mm
Displacement	2.216 litres
Direction of rotation	Anti-clockwise viewed on flywheel
Cooling system	Water cooled
Total coolant capacity	7.0 litres
Total Lubrication system capacity	10.6 litres
Length	946 mm
Width	497 mm
Height	840 mm
Total weight (dry)	242 kg

Final weight and dimensions will depend on completed specification.

Distributed by